NOTES

MISCELLANEOUS CABINET REPAIRS



Counter Top Removal

TOP REMOVAL FOR TSSU, TWT, TUC MODELS

INSTALLATION INSTRUCTIONS

1. Disconnect power from cabinet.
2. Unscrew the top door hinges from underside of the counter top and remove the door (2).
3. Locate and remove two 3" screws in the black plastic trim in the top of the door or drawer opening. This will have to be done for each door or drawer opening.
4. Cut the black silicone seal on the outside of the cabinet that seals the counter top to the cabinet. Cut any white silicone seal on the inside of the cabinet.
5. Lift up on the front of the counter top to about 45° angle and push then push the top towards the rear of the cabinet and remove the top. The counter top slips into a groove on the rear of the cabinet.
6. Clean all the excess silicone from the inside and outside of the cabinet.
7. To reinstall, place a bead of black silicone on the outside edge of the cabinet.
8. Place the backside of the counter top on the cabinet in its groove, maintaining the cabinet top at a 45° angle at all times. Be sure to square the cabinet up on each side before putting the top down.
9. Reinstall all the screws through the top of the door opening. If you are installing a new counter top you will have to drill a 8/32" hole into the top. Use the existing holes in the horizontal cabinet support as your guide.
10. Silicone the inside of the cabinet with white silicone if you need to.
11. Reinstall the doors.

The following steps help to install a new counter top.

1. Follow step #8, you will need to pre-drill a 8/32" hole to install the 3" screws through the door/drawer opening.
2. Lay the cabinet on its back, place a 5/8" shim on the outside edge of the cabinet. Place the doors into position with the outside edge of the door aligned with the edge of the cabinet.
3. Push the mounting plate on the KEIL hinge until it's parallel with the front of the cabinet and mark the center of the hinge holes. Drill a hole with a #7 or .201 drill bit. Install the door on the cabinet, be sure to place the black plastic spacer between the hinge bracket and the counter top and run the screws into the new holes and then remove the shims.
4. Check the operation of the door (s)

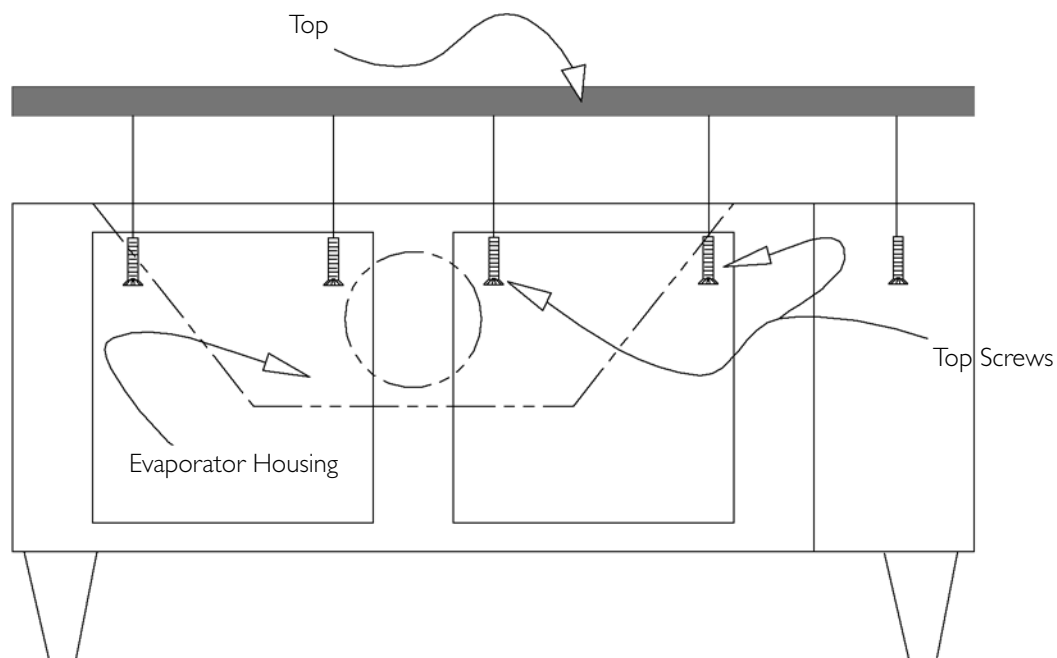

TPP COUNTERTOP REPLACEMENT INSTRUCTIONS

INSTALLATION INSTRUCTIONS

1. Unscrew top door hinges from underside of counter top and remove doors.
2. Remove the front louvered grill. Remove the screw from the L-bracket that connects the counter top to the cabinet.
3. Locate and remove two 3" screws in the black plastic trim in the top of the door or drawer opening. This will have to be done for each door or drawer opening.
4. Remove screws from the following parts inside of cabinet.
 - A. Air-duct, which extends from evaporator housing to far left end of cabinet. (After all screws are removed lower duct into cabinet floor).
 - B. Fan area housing (after air duct is lowered, screws connecting this housing to the counter top will be exposed, remove these screws)
5. Cut the black silicone seal on the outside of the cabinet that seals the counter top to the cabinet.
8. Clean all the excess silicone from the inside and outside of the cabinet.
9. To reinstall, place a bead of black silicone on the outside edge as well as from the front to back between the cabinet end and the evaporator section on the cabinet.
10. Place the backside of the counter top on the cabinet in its groove, maintaining the cabinet top at a 45° angle at all times. Be sure to square the cabinet up on each side before putting the top down.
11. Reinstall all the screws through the top of the door opening. If you are installing a new counter top you will have to drill a 8/32" hole into the top. Use the existing holes in the horizontal cabinet support as your guide. Holes in the top should align with the holes in the frame. Reinstall the L-bracket
12. Reinstall the screws into the interior parts, first the pan area housing and then the air duct.
13. Silicone the inside of the cabinet with white silicone.

NOTE: There may also be a silicone seal that runs from front to back above the condensing unit section on the left inside edge.

6. Cut any white silicone seal on the inside of the cabinet.
 7. Lift up on the front of the counter top to about a 45° angle and push then push the top towards the rear of the cabinet and remove the top. The counter top slips into a groove on the rear of the cabinet.
- The following steps help to install the new counter top.**
1. Follow step # 11, you will have to pre-drill 8/32" hole to install the 3" screws through the door / drawer opening.
 2. Lay the cabinet on its back, place doors into position. Mark the holes for hinges. Pre-drill these holes with a 8/32" drill bit. Mount doors.

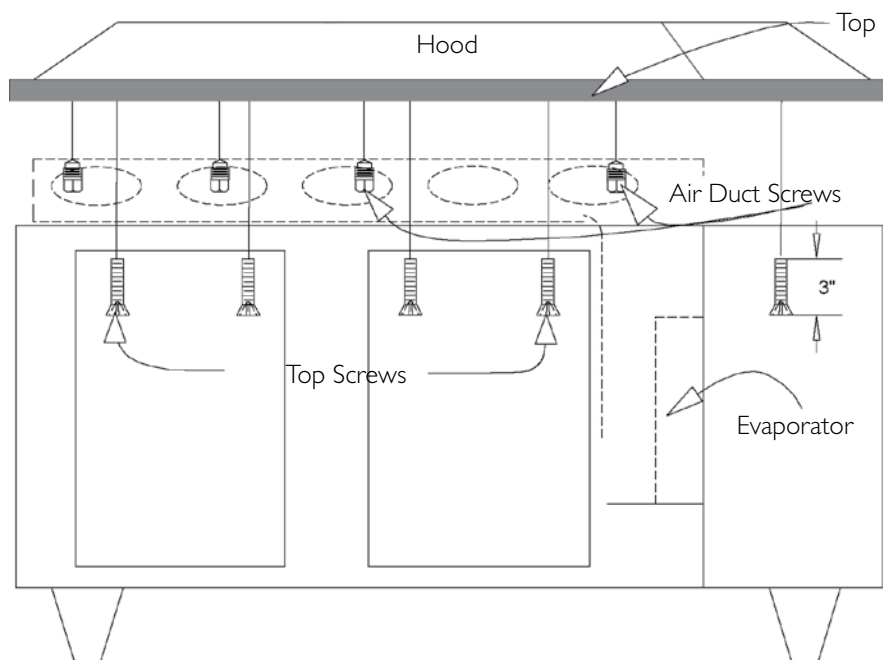

TOP REMOVAL FOR TD & T-GC UNITS

INSTALLATION INSTRUCTIONS

1. Turn unit off and remove lids.
2. Remove screws along back of cabinet top.
3. Remove screws on each side, going through lid slide rails, inside cooler.
4. Remove screws along front of top under inside ledge, also remove the two screws holding center trunion on units with more than one door.
5. Lift top to approximately 45 degrees while pushing top forward at same time. Top will lift off lip in front. T-50-GC has heater wire looped through center trunion. Please be careful when removing top. Before reinstalling, inspect heater wire to make sure it is not damaged.
6. To reinstall top, while holding top at 45 degree angle hook top on lip at front of cabinet and lay down while pushing backwards on top, when laid completely down press firmly on top to provide a good seal.
7. Reinstall all screws along inside of cabinet and along back of top on outside of cabinet.
8. Reinstall doors and turn unit on.

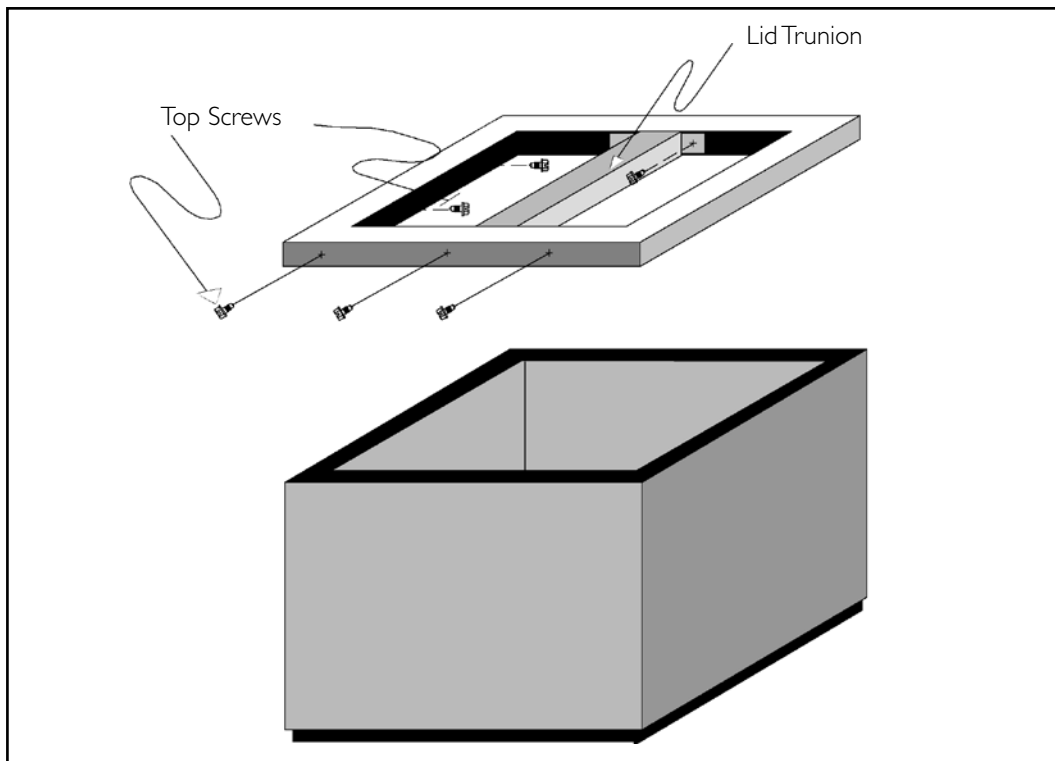

TOP REMOVAL FOR TBB & TDD UNITS

INSTALLATION INSTRUCTIONS

1. Disconnect the power to the unit.
2. Locate and remove screws securing the evaporator housing to the bottom of the counter top. See Illustration 1. (Except TBB-1/TDD-1)
3. Locate and remove the screws securing the refrigeration lines cover located to the left of the evaporator inside the cabinet. (Except TBB-1)
4. Locate and remove the screws inside the door jamb going through the jamb into the underside of the counter top. There should be two screws in each door opening on multiple door units. See Illustration 1.
5. Locate and remove the screw on the left outside of the cabinet under the counter top. This screw should be through a bracket. See image 1. NOTE: This bracket might not be used on older models. (Except TBB-1/TDD-1)
6. Cut the silicone seal that runs along both ends and along the front and back of the cabinet. We recommend using a putty knife to do this.
7. To remove the counter top, lift up 2-4 inches on the front of the counter top and push the top backward to unlock the counter top from the cabinet.
8. To reinstall the top, carefully align the groove in the underside of the counter top with the black plastic lip on the cooler base. Slide forward and reinstall all screws and re-silicone around cabinet edge.

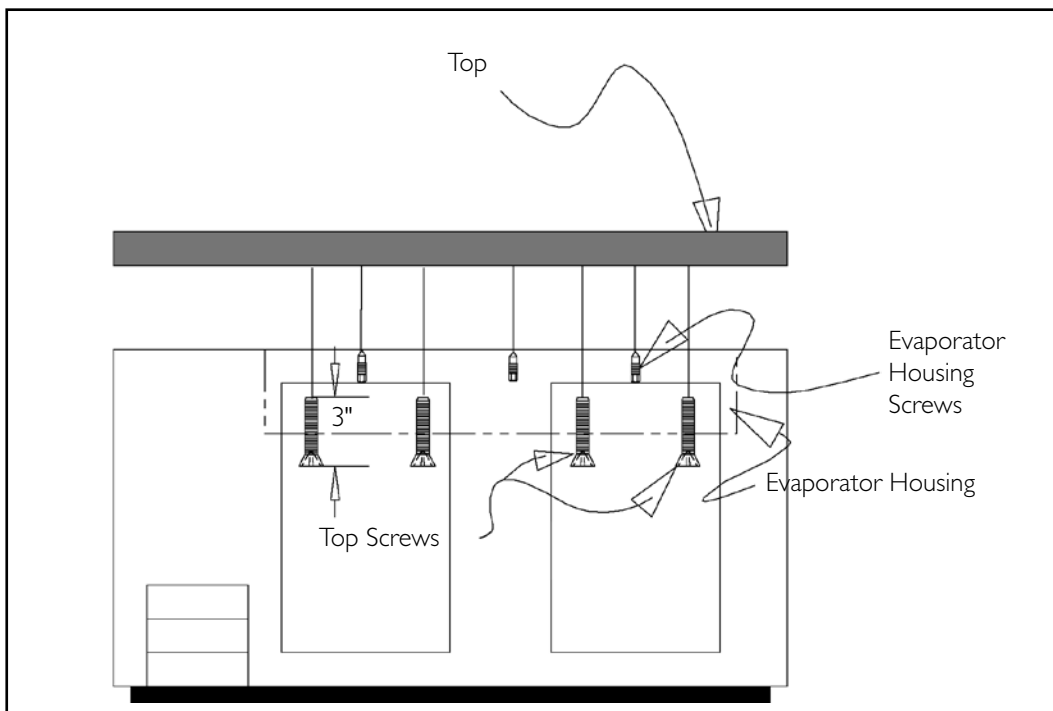

Illustration 1

NOTES
